

THE OPTIMIZATION OF TIME AND COST PROCESS TECHNIQUE

Barković, Dražen; Jukić, Josip

Source / Izvornik: **Ekonomski vjesnik : Review of Contemporary Entrepreneurship, Business, and Economic Issues, 2017, 30, 287 - 300**

Journal article, Published version

Rad u časopisu, Objavljena verzija rada (izdavačev PDF)

Permanent link / Trajna poveznica: <https://um.nsk.hr/um:nbn:hr:145:970409>

Rights / Prava: [Attribution-NonCommercial-NoDerivatives 4.0 International/Imenovanje-Nekomercijalno-Bez prerada 4.0 međunarodna](#)

Download date / Datum preuzimanja: **2024-09-20**



Repository / Repozitorij:

[EFOS REPOSITORY - Repository of the Faculty of Economics in Osijek](#)



Dražen Barković

*Josip Juraj Strossmayer University of Osijek
Faculty of Economics in Osijek
Trg Ljudevita Gaja 7,
31000 Osijek, Croatia
barkovic@efos.hr
Phone: +385912244021*

UDK: 519.852

Original scientific article

Received: October 7, 2016

Accepted for publishing: February 9, 2017

Josip Jukić

*College of Slavonski Brod
Dr. Mile Budaka 1,
35000 Slavonski Brod, Croatia
josip.jukic@vusb.hr
Phone: +38535492800*

This work is licensed under a
Creative Commons Attribution-
NonCommercial-NoDerivatives 4.0
International License



THE OPTIMIZATION OF TIME AND COST PROCESS TECHNIQUE

ABSTRACT

The critical path method (CPM) and linear programming are two closely related operations research techniques. Some of their concepts are presented in this paper in order to review some recent modelling structures that have been particularly valuable in the analysis of project time-cost crashes problems.

The activities underwent crashing of both the time and cost using linear programming. A simplified representation of a small project and a linear programming model were formulated to represent this system. In addition to being simple, the advantage of this method is that it is applicable to large networks. It allows for a shorter computational time at a lower cost, whereas robustness is increased.

Keywords: Critical path method, linear programming, time crashing, maintenance

1. Introduction

Any maintenance project represented by networks consists of a number of activities. These activities are represented in a network by arrows. They are a clearly definable task to which a known quantity of resources will be applied and hence always take time. The interdependence of activities indicates the relationship between different activities. For any project, the first event represents the starting point and the last event represents the completion point (Elmabrouk, 2012: 24). The best way to guarantee success of any type of maintenance project is to have a strong, experienced project manager and a strong, experienced business analyst. To be on time, it is required to complete the maintenance project within the predetermined deadline to keep cost at the lowest possible level by a reliable technique. For the deadline to be achieved, some projects require to minimize their completion time by crashing their critical activities.

This paper mainly provides a framework for crashing total maintenance project time at the least total cost by using PERT/CPM cost analysis and the Linear Programming technique. A prototype example of vehicle repair is used to show how this technique is used for strategic decision making and assisting managers dealing with crashing maintenance projects activities.

Modern technical systems are composed of a large number of parts, sub-assemblies and assemblies. Any such system has a specific purpose, which is mainly to perform a determined function within the set limits of quality. For the technical system to work, its parts must be in a mutual functional relationship, either static or dynamic. Due to such relationships, there is an interaction among parts that leads to overloads, wearing out (especially in the case of dynamic relations) and damages. Such deterioration of parts and their interconnections leads to a decline in the function performance quality of the system as a whole.

When the quality level drops below the determined lower limit, the technical system is in the fault condition. One should add to this that there are two important factors that have an important impact on the functioning of the system – the human and environment factor. The way of handling the system, conducting operation methods, the temperature, humidity, corrosion, and soil conditions do reflect on the performance of the technical system. This implies the necessity to take certain measures in order to keep the system functioning.

Maintenance of a technical system represents a business function which implies maintenance of machines, devices, appliances, plants, buildings, pathways and other means related to work, intended to fulfil the overall business task of the production system. The process of maintaining the system in good working order should act in the first place, to prevent the occurrence of faults, but if failures occur they should be removed as best possible and in the shortest time possible. Thus, the meaning of maintenance functions is reflected in the possibility of reducing system down time to a minimum. If one manages to achieve the usable capacity of the system, equal or close to the capacity prior to the down time, the maintenance function has served its purpose.

Even tough new maintenance strategies have been applied to enable reliability and extended lifespan of equipment, remounts have remained for numerous technical systems a significant opportunity to restore technical systems and enable them to work in accordance to the designed operational parameters as well as to extend their lifetime.

2. Optimization tasks

The optimal managing implies the selection of controlled actions that have to provide the greatest effect according to constrains and selected criteria, finding an alternative with the most cost effective or highest achievable performance under the given constraints, by maximizing desired factors and minimizing undesired ones. In comparison, maximization means trying to attain the highest or maximum result or outcome without regard to cost or expense. Practice of optimization is restricted by the lack of full information, and the lack of time to evaluate what information is available. In computer simulation (modelling) of business problems, optimization is achieved usually by using linear programming techniques of operations research.

The task shown in Figure 1. is the necessity to move through the system from the initial state a_p to the desired state a_k .

Figure 1 Set of possible trajectories for transition from a_p to a_k

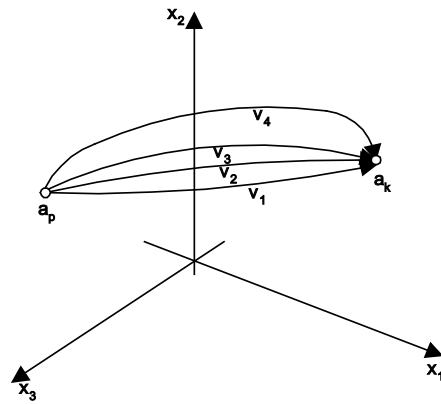

Source: Authors

Several variants ($v_1, v_2 \dots v_n$) can be chosen to achieve the goal. Each variant has different value of the fitness function that becomes a criterion for the selection of optimal variant.

Today, theory of optimal managing has reached a high level of development.

Management tasks that appear in the organization of production systems are very various. The tasks can be divided into two groups: operational and functional.

When considering the production management system, operation tasks are:

- inventory management
- maintenance management
- choice of development strategy
- production management
- the choice of marketing strategy
- human resource education management
- asset management.

Functional tasks have to ensure the required flow of technological operations, to harmonize the work of organizational units, etc.

Quantitative methods or operational research methods are developed as tools for solving the problem of managing of production systems.

The methods can be grouped as follows:

- Linear programming (inclusive transportation and assignment methods, integer programming and 0-1 programming),

- Non-linear programming,
- Optimal reservation,
- Heuristic programming,
- Game Theory,
- Waiting line, and
- CPM/PERT.

The critical path method (CPM) and project evaluation and review technique (PERT) are two commonly used techniques for developing and monitoring projects. Although each technique was developed independently and for expressly different purposes, time and practice have erased most of the original differences, so that now there is little distinction between the two. Both provide the manager with a rational approach to project planning and graphical display of project activities. Also, both depict the sequential relationships that exist among activities and reveal to managers which ones must be completed on time to achieve timely project completion. Managers can use that information to direct their attention toward the most critical activities. The task of developing and quickly updating project networks quickly becomes complex for projects of even moderate size, so computer software is important (Stevenson, 1989: 640).

Linear Programming (LP) Problem

The general linear programming problem is one in which we are to find the maximum or minimum value of a linear expression (Dilworth, 1992: 676):

$$z = c_1 x_1 + c_2 x_2 + \dots + c_n x_n$$

(called the objective function), subject to a number of linear constraints of the form

$$a_{11}x_1 + a_{12}x_2 + \dots + a_{1n}x_n \leq b_1$$

$$a_{21}x_1 + a_{22}x_2 + \dots + a_{2n}x_n \leq b_2$$

.....

$$a_{m1}x_1 + a_{m2}x_2 + \dots + a_{mn}x_n \leq b_m$$

$$x_1 \geq 0 \quad x_2 \geq 0 \quad \dots \quad x_n \geq 0$$

Where

a_{ij}, b_i, c_j = given constants

x_j = variable selected by the process (that is, decision variable)

n = number of decision variable

m = number of constraints

The largest or smallest value of the objective function is called the optimal value. Depending on the problem, the constraints may also be stated with equal signs (=) or greater- than – or equal- to signs (\geq).

The complex practice managing tasks usually have to meet not just one criterion but a specific set of criteria.

Making a proper decision can be very difficult because the nature of the present goals is diametrically opposed. Such kind of problem cannot be solved through optimization of individual goals because in the general case the given solution can be useless. The achieved solutions are able to fulfil just some of the set goals but most of them will remain more or less unfulfilled.

The general postulate of the mathematical model for the mentioned tasks, in the case that a linear relationship exists between the variables, has the form (Jukić, 2000: 104):

$$\max \sum_{j=1}^n c_{kj} x_j, \quad k = \overline{1, p}$$

$$\sum_{j=1}^n a_{ij} x_j \begin{cases} \leq \\ = \\ \geq \end{cases} b_i, \quad i = \overline{1, m}$$

$$x_j \geq 0, \quad j = \overline{1, n}$$

where p = number of criteria, m = number of constraints, n = number of variables, c_{kj} = coefficients k -th criteria function by j -th variable, a_{ij} – elements of constraints matrix and b_i - elements in vector free members of constraints.

This problem tackles the issue of multi-objective optimization which considers optimization problems involving more than one objective function to be optimized simultaneously. Furthermore, multi-objective optimization problems arise in many fields, such as engineering, economics, and logistics, when optimal decisions need to be taken in the presence of trade-offs between two or more conflicting objectives. For example, developing a new component might involve minimizing weight while maximizing strength or choosing a portfolio might involve maximizing the expected return while minimizing the risk.

Typically, there does not exist a single solution that simultaneously optimizes each objective. Instead, there exists a (possibly infinite) set of Pareto optimal solutions. A solution is called *non-dominated* or *Pareto optimal* if none of the objective functions can be improved in value without degrading one or more of

the other objective values. Without additional subjective preference information, all Pareto optimal solutions are considered equally good. Mathematically, the multi-objective optimization problem can be regarded as solved when the Pareto optimal set has been determined. In practical applications, however, the designer wants only one optimal solution and it is required to introduce some preferences in order to find the best solution among Pareto optima.

Traditionally, problems with several competing criteria were reformulated by using one criterion or scalar objective function and the multi-objective nature of the original problem was more or less hidden. One popular approach is to combine all the criteria into one scalar objective function. Another well-known approach is to choose one of the criteria as the objective function and transform the others into constraints. These techniques may look reasonable, but they have proven to have several shortcomings (Grosan et al., 2007).

3. Optimization of the duration of maintenance in relation to the cost method, "PERT COST"

This is because the idea of economy is closely tied to the success of the company that is dependent on the costs (Holjevac, 1993). It can be concluded that all economic decisions are based on cost, so special attention should be given to cost management. To provide maintenance of a technical system with maximum reliability it is equally important how to minimize maintenance costs. If it tends to produce more products, it is possible that maintenance costs can significantly reduce the earnings (Figure 2).

Figure 2 The time-cost trade-off

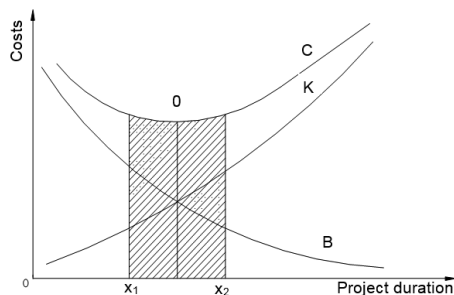

K - Indirect costs, *B* - Direct costs, *C* - Total project costs, *O* - Optimal costs, x_1 - minimal boarder of optimal cost region, x_2 - maximal boarder of optimal cost region

Source: Tomić, M., Adamović, Ž. (1986). *Pouzdanost u funkciji održavanja tehničkih sistema*. Beograd: Tehnička knjiga.

Experience shows that one cannot talk exactly about the optimum point of maintenance and down time. When the minimum is considered, it is the interval between x_1 and x_2 .

In our discussion of project crashing, we demonstrate how the project critical path time could be reduced by increasing expenditures for labour and direct resources. The implicit objective of crashing is to reduce the scheduled completion time for its own sake- that is, to reap the results of the project sooner. However, there may be other important reasons for reducing project time. As projects continue over time, they consume various direct and indirect costs.

Cost assignment is the process of assigning costs to cost pools or from cost pools to cost objects. A direct cost can be conveniently and economically traced directly to a cost pool or a cost object. For example, the cost of materials required for a particular product is direct cost because it can be traced directly to the product. Direct costs are, for example, direct construction payment, spare parts and construction parts. In contrast, there is no convenient or economical way to trace an indirect cost from the cost to the cost pool or from the cost pool to the cost object. The cost of supervising manufacturing employees and the cost of handling materials are good examples of costs that generally cannot be traced to individual products and therefore are indirect costs for the products.

In general, project crash costs and indirect costs have an inverse relationship; crash costs are highest when the project is shortened, whereas indirect costs increase as the project duration increases. This time-cost relationship is illustrated in Figure 2. The best, or optimal, project time is at the minimum point of the total cost curve.

Each activity can be performed with lower or higher costs. This will certainly affect the duration of the activity. According to this, the normal costs will have a normal duration.

To speed up the duration of activities will increase the costs such as multiple machines, the number of employees, work on non-working days, extended work, etc.

The various dependencies between the cost and duration of the activity are shown in Figure 3 where the X-axis or abscissa is time and the ordinate or Y-axis is direct costs.

Figure 3 Relationship between direct costs and project duration

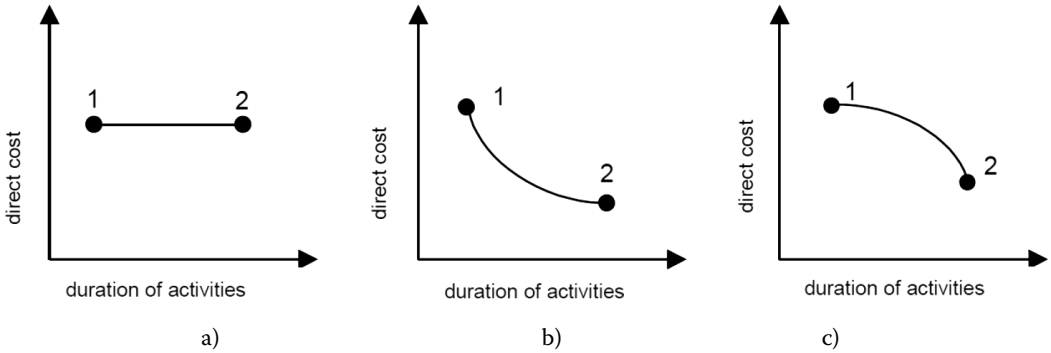

Source: Vila, A., Leicher, Z. (1983). *Planiranje proizvodnje i kontrola rokova*. Zagreb: Informator.

In Figure 3 a), b) and c) point 1 is the minimum duration of the activities with additional cost (using overtime, using other services etc.). Point 2 represents the duration of the activity with minimal costs. Different calculations can be made between these two points. Some principles can be seen:

a) Shortening or extending an activity's duration, the costs are constant,

b) Extending an activity's duration, the costs fall on a concave curve,

c) Extending an activity's duration, the costs fall on a convex curve.

For further processing of costs optimization, the linear approximation (for auxiliary calculations (estimates)) between point 1 and 2 (Figure 4) will be taken.

Figure 4 Time-costs relationship for crashing activity

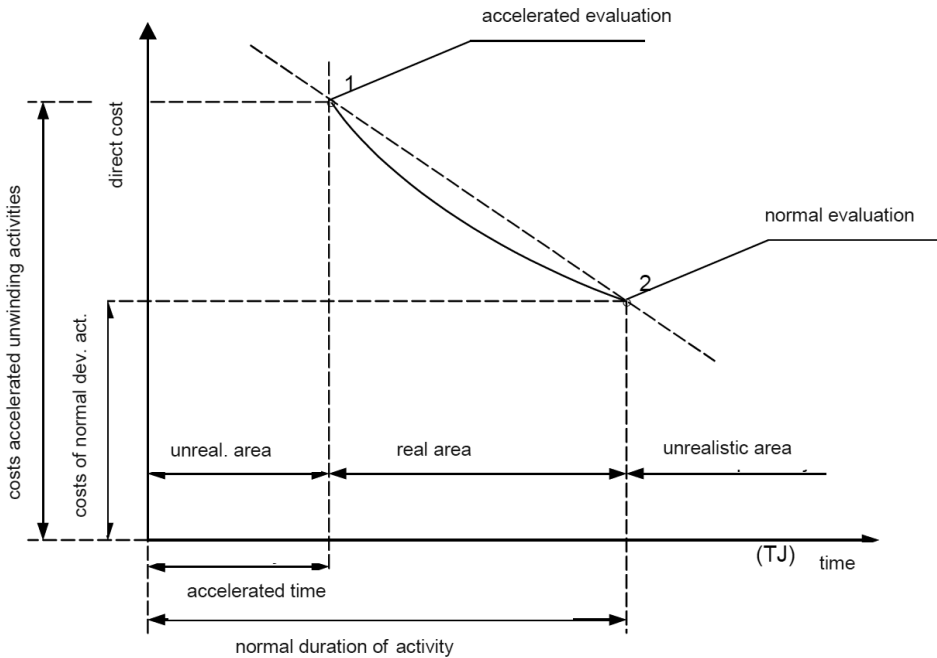

Source: Čala, I. (1983). *Održavanje i remont*. Zagreb: Fakultet strojarstva i brodogradnje.

The points 1 and 2 represent two extremes of time and cost estimation, so point 1 will be called accelerated estimated time, and point 2 will be called normal estimated time and costs.

Accelerated estimation means that some activity will be performed in a minimum of time and with the necessary costs. That means that the emphasis is on time.

Normal estimation means that some activity will be performed with minimum cost. That means that the price is relevant and will be taken into consideration.

Auxiliary estimations are all points between 1 and 2. The cost “C” and time “t” are involved in figure 4. Characteristic values are:

- t_n - normal time, the time associated with each normal cost
- t_u - crash time, the shortest possible activity time
- C_n - normal cost, the lowest expected activity cost
- C_u - crash cost, the cost associated with each crash time.

By applying the PERT/COST network, better project managing will be achieved and the project costs will be decreased. Planning is done through network planning. On the same network model, besides the analysis of time, the analysis of costs will be done (Islam et al., 2004).

Activities on the critical path are potential candidates for crashing because shortening non-critical activities would not have an impact on total project duration. From an economic standpoint, activities should be crashed according to crash costs: Crash those with the lowest costs first. Moreover, crashing should continue as long as the cost to crash is less than the benefits received from crashing. These benefits might take the form of incentive payments for early completion of the project as part of a government contract, or

they might reflect savings in indirect costs, direct, and total project costs due to crashing.

The general procedure for crashing is (Stevenson, 1989: 641):

1. Obtain estimates of regular and crash times and crash times and costs for each activity.
2. Determine the lengths of all paths and path slack times.
3. Determine which activities are on the critical path.
4. Crash critical activities, in order of increasing costs, as long as crashing costs do not exceed benefits (Note that two or more paths may become critical as the original critical path becomes shorter, so that subsequent improvements will require simultaneous shortening of two or more paths). In some cases it will be most economical to shorten an activity that is on two, or more, of the critical paths. This is true whenever the crashing cost for a joint activity is less than the sum of crashing one activity on each separate path.

4. Two closely related operations research techniques for optimization times and costs

For the optimal calculation of the project duration, the example of vehicle repair has been chosen. Out of many, there have been 6 (six) main activities chosen in order to encompass the complete repair of one vehicle.

The team assigned to the General Maintenance project has estimated the duration of each of the six major activities.

Table 1 Activity list for the General Maintenance project

Activity	Start node	End node	Activity time
A – Acceptance of technical system and determining of technical system	1	2	15
B – Dismantling (disassembly of technical system)	1	3	7
C – Motor overhaul	2	4	4
D – Overhaul of other installation	3	4	6
E – Installation (assembly) of technical system	2	5	12
F – End control and testing	4	5	4

Source: Authors

We drew a network diagram for this project, i.e. activity on arrow network. The calculation was made based on the forward pass-backward pass, i.e. the duration of the project was calculated to be 27 weeks and the critical path are activities (1-2) and (2-5).

The activities have been put into the POM program (Weiss, 2006) with their duration time in order to make a calculation of the early start and late finish of activities for each event, after which the critical path was determined.

Figure 5 Network diagram for the General Maintenance project

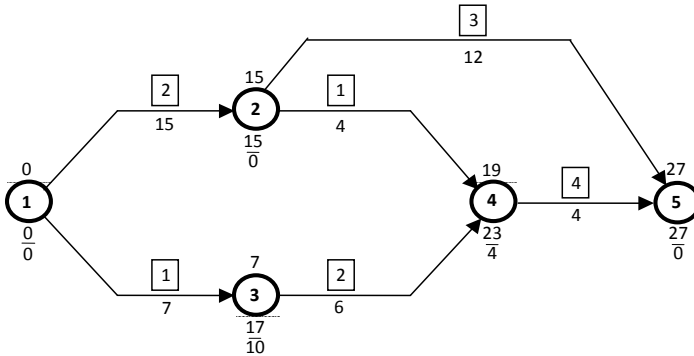

Source: Authors

Table 2 The earliest start, earliest finish, latest start, latest finish times of General Maintenance project

Activity	Start node	End node	Activity time	Early Start	Early Finish	Late Start	Late Finish	Slack
Project			27					
A	1	2	15	0	15	0	15	0
B	1	3	7	0	7	10	17	10
C	2	4	4	15	19	19	23	4
D	3	4	6	7	13	17	23	10
E	2	5	12	15	27	15	27	0
F	4	5	4	19	23	23	27	4

Source: Authors

Result: the critical path represents those activities in which the slack variable is 0. These are A (1-2) and E (2-5) in total duration of 27 weeks. This duration is not satisfactory because the normal business flows are jeopardized. This is due to the following reasons:

- The duration of project has been limited by the beginning of the vehicle use. Planned reassembly deadlock of the vehicle use is 13 to 20 weeks and this is the time in which all the activities of the repair should be completed. Each prolongation over the 20 weeks significantly increases the cost (of another vehicle rent).

The application of PERT/COST in our example, at the same network diagram, should:

- provide more reliable and real estimation of the project duration, i.e. crashing of particular activities;
- bring the project back to the determined time framework;
- provide more reliable and real estimation of project costs (repair) and choice of optimal solution;
- provide an explicit improvement in the control and more efficient use of planned means.

The company cannot meet the deadline unless it is able to shorten some of the activity times. This process of shortening a project, called crashing, is usually achieved by adding extra resources (such as equipment or people) to an activity. Naturally, crashing costs more money, and managers are usually interested in speeding up a project at the least additional cost.

4.1 Project Crashing with QM for Windows

QM for Windows has the capability to crash a network *completely*. In other words, it crashes the network by the maximum amount possible. The QM for Windows solution for our example is shown in Table 3 (costs in 000 \$).

Table 3 Project Management (PERT/CPM) Results

Activity	Start node	End node	Normal time	Crash time	Normal Cost	Crash Cost	Crash cost/pd	Crash by	Crashing cost
Project			27	13					
A	1	2	15	7	2	6	.5	8	4
B	1	3	7	3	1	5	1	2	2
C	2	4	4	1	1	8.5	2.5	0	0
D	3	4	6	2	2	10	2	0	0
E	2	5	12	6	3	15	2	6	12
F	4	5	4	2	4	7	1.5	2	3
Totals					13				21

Source: Authors

The results are as follows. The software finds the normal time 27 weeks and the minimum time 13 weeks, at the total crashing costs \$21,000. For each activity the computer finds the cost of crashing per period (crash cost – normal cost) / (normal time – crash time), which activities should be crashed and by how much, and the prorated cost of crashing.

A week-by-week crash schedule is available as follows. For example, to reduce the project to 13 weeks, read across the line with a project time of 13 weeks. The cost for reducing the project from 14 to 13 weeks is \$3,500. The total cost of reducing the project from 27 weeks to 13 weeks is \$21,000. The activities to crash to achieve 13 weeks are A by 8 days, B by 2, E by 6, F by 2 (Table 4).

Table 4 Crash schedule

Project time	Period cost	Cumulative cost	A	B	C	D	E	F
27	0	0	1					
26	.5	.5	2					
25	.5	1	3					
24	.5	1.5	4					
23	.5	2	5					
22	.5	2.5	6					
21	.5	3	7					
20	.5	3.5	8					
19	.5	4	8					
18	2	6	8				1	
17	2	8	8				2	
16	3	11	8	1			3	
15	3	14	8	2			4	
14	3.5	17.5	8	2			5	1
13	3.5	21	8	2			6	2

Source: Authors

From Table 3 (column 5 and column 7) one gets crash times of activities. The earliest times are determined using the forward pass through the net-

work and the latest times are computed using the backward pass. So, we computed many critical paths: 1-2-5, 1-3-4-5.1-2-4-5.

Figure 6 Network diagram

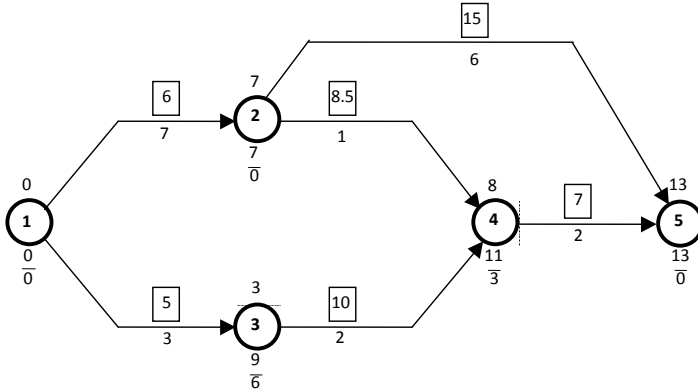

Source: Authors

4.2 Linear programming method

Linear programming is a tool for decision making under certain circumstances. The basic assumption of this approach is that we have to know some relevant data with certainty. The basic data requirements are as follows (Elmabrouk, 2012):

- a) We have to know the project network with activity time, which can be achieved from PERT and CPM.
- b) To what extent an activity can be crashed.
- c) The crash cost associated with per unit of time for all activities.

To reduce the time to complete the activity, more resources are applied in the form of additional personnel and overtime. As more resources are applied, the duration is shortened, but the cost rises. Maximum effort is applied so that the activity can be completed in the shortest possible time. The equation for the cost slope is

$$U_i = \frac{C_c - C_n}{T_n - T_c} \tag{1}$$

Where:

U_p , C_c and C_n are the cost slope, the crash cost and normal costs, respectively. T_c and T_n are the crash and normal times, respectively. The cost slope shows

by how much the cost of the job would change if the activities were speeded up or slowed down. Before formulating the model, some relevant terms will be defined. It is very well known that a project is the combination of some activities, which are inter-related in a logical sequence in the sense that the starting of some activities is dependent upon the completion of some other activities. These activities are jobs which require time and resources to be completed. The relationship between the activities is specified by using an event. As an event represents a point in time that implies the completion of some activities and the beginning of new ones, the beginning and end point of an activity are thus expressed by two events.

Now let's define the variable of the problem (Taylor, 2010: 388-389).

X_i = earliest event time of node i when an event i will occur, measured since the beginning of the project, where $i = (1, 2, 3, \dots, n)$.

X_j = earliest event time of node j.

Y_{ij} = amount of times (measured in terms of days, weeks, months or some other units) that each activity i will be crashed, where $i = (1, 2, 3, \dots, n)$.

The objective is to minimize the cost of crashing the total project via minimizing the durations of crashing activities that are multiplied by their associated cost slope, then the resultant cost is added to the

normal cost of project completion. The LP objective function will be:

$$\min z = \sum_{i=1}^n U_i Y_i$$

This objective function is subject to some constraints. These constraints can be classified into three categories (Elmabrouk, 2012).

Crash time constraints: We can reduce the time to complete an activity by simply increasing the resources or by improving the productivity, which also requires the commitment of additional resources. But, it is not possible to reduce the required time to complete an activity after a certain threshold limit. Striving for such a goal will result in superfluous resources employment which will be an inefficient approach. That is why the allowable time to crash an activity has a limit. Constraints unfolding the network: These set of constraints describe the structure of the network. As we mentioned earlier, the activities of a project are interrelated, the starting of some activities is dependent upon the completion of some other activities; we have to establish the research sequence of the activities through constraints.

Nonnegative constraints: All decision variables must be ≥ 0 . So, the constraints are:

Crash time constraints: $Y_{ij} \leq$ Allowable crashing time for activity i measured in terms of days, weeks, months or other units.

Constraints unfolding the network: there will be one or more constraints for each event depending on the predecessor activities of that event. As the event 1 will start at the beginning of the project,

we begin by setting the occurrence time for event 1 equals to zero. Thus $X_1 = 0$. The other events will be expressed as follows:

The start time of this activity (X_i) = (start time + normal duration – crash duration) for this immediate predecessor.

Project completion constraints: $X_m \leq$ project deadline after being stretched, there m indicates the last event of that project. This constraint will recognize that the last event (completion of the last activities) must take place before the project deadline data.

$$\text{Min } .5Y_{12} + Y_{13} + 2.5Y_{24} + 2Y_{34} + 2Y_{25} + 1.5 Y_{45}$$

$$X_5 \leq 13$$

$$X_2 + Y_{12} \geq 15$$

$$X_3 + Y_{13} \geq 7$$

$$-X_2 + X_4 + Y_{24} \geq 4$$

$$-X_3 + X_4 + Y_{34} \geq 6$$

$$-X_2 + X_5 + Y_{25} \geq 12$$

$$-X_4 + X_5 + Y_{45} \geq 4$$

$$Y_{12} \leq 8$$

$$Y_{13} \leq 4$$

$$Y_{24} \leq 3$$

$$Y_{34} \leq 4$$

$$Y_{25} \leq 6$$

$$Y_{45} \leq 2$$

$$X_i, Y_{ij} \geq 0$$

Table 5 Linear programming formulation - POM-QM FOR WINDOWS

	X1	X2	X3	X4	X5	Y12	Y13	Y24	Y34	Y25	Y45		RHS	Equation form
Minimize	0	0	0	0	0	.5	1	2.5	2	2	1.5			Min .5Y12+Y13+2.5Y24+2Y34+2Y25+1.5Y45
Constraint 1	0	0	0	0	1	0	0	0	0	0	0	<=	13	X5<=13
Constraint 2	0	1	0	0	0	1	0	0	0	0	0	>=	15	X2+Y12>=15
Constraint 3	0	0	1	0	0	0	1	0	0	0	0	>=	7	X3+Y13>=7
Constraint 4	0	-1	0	1	0	0	0	1	0	0	0	>=	4	-X2+X4+Y24>=4
Constraint 5	0	0	-1	1	0	0	0	0	1	0	0	>=	6	-X3+X4+Y34>=6
Constraint 6	0	-1	0	0	1	0	0	0	0	1	0	>=	12	-X2+X5+Y25>=12

	X1	X2	X3	X4	X5	Y12	Y13	Y24	Y34	Y25	Y45		RHS	Equation form
Constraint 7	0	0	0	-1	1	0	0	0	0	0	1	>=	4	-X4+X5+Y45>=4
Constraint 8	0	0	0	0	0	1	0	0	0	0	0	<=	8	Y12<=8
Constraint 9	0	0	0	0	0	0	1	0	0	0	0	<=	4	Y13<=4
Constraint 10	0	0	0	0	0	0	0	1	0	0	0	<=	3	Y24<=3
Constraint 11	0	0	0	0	0	0	0	0	1	0	0	<=	4	Y34<=4
Constraint 12	0	0	0	0	0	0	0	0	0	1	0	<=	6	Y25<=6
Constraint 13	0	0	0	0	0	0	0	0	0	0	1	<=	2	Y45<=2

Source: Authors

Table 6 Project Crashing with Linear programming – Results

	X1	X2	X3	X4	X5	Y12	Y13	Y24	Y34	Y25	Y45		RHS	Dual
Minimize	0	0	0	0	0	.5	1	2.5	2	2	1.5			
Constraint 1	0	0	0	0	1	0	0	0	0	0	0	<=	13	3-5
Constraint 2	0	1	0	0	0	1	0	0	0	0	0	>=	15	-2-5
Constraint 3	0	0	1	0	0	0	1	0	0	0	0	>=	7	-1
Constraint 4	0	-1	0	1	0	0	0	1	0	0	0	>=	4	--5
Constraint 5	0	0	-1	1	0	0	0	0	1	0	0	>=	6	-1
Constraint 6	0	-1	0	0	1	0	0	0	0	1	0	>=	12	-2
Constraint 7	0	0	0	-1	1	0	0	0	0	0	1	>=	4	-1.5
Constraint 8	0	0	0	0	0	1	0	0	0	0	0	<=	8	2
Constraint 9	0	0	0	0	0	0	1	0	0	0	0	<=	4	0
Constraint 10	0	0	0	0	0	0	0	1	0	0	0	<=	3	0
Constraint 11	0	0	0	0	0	0	0	0	1	0	0	<=	4	0
Constraint 12	0	0	0	0	0	0	0	0	0	1	0	<=	6	0
Constraint 13	0	0	0	0	0	0	0	0	0	0	1	<=	2	0
Solution	0	7	5	11	13	8	2	0	0	6	2		21	

Source: Authors

Table 7 Solution summary by using the POM program

Variable	Value	Reduced Cost	Original Val	Lower Bound	Upper Bound
X1	0	0	0	0	Infinity
X2	7	0	0	-2	Infinity
X3	5	0	0	-.5	1
X4	11	0	0	-.5	2
X5	13	0	0	Infinity	3.5
Y12	8	0	.5	-Infinity	2.5
Y13	2	0	1	0	1.5

Variable	Value	Reduced Cost	Original Val	Lower Bound	Upper Bound
Y24	0	2	2.5	.5	Infinity
Y34	0	1	2	1	Infinity
Y25	6	0	2	0	Infinity
Y45	2	0	1.5	1	3.5
Constraint 1	3.5	0	13	13	15
Constraint 2	-2.5	0	15	13	15
Constraint 3	-1	0	7	5	9
Constraint 4	-.5	0	4	2	4
Constraint 5	-1	0	6	4	8
Constraint 6	-2	0	12	6	12
Constraint 7	-1.5	0	4	2	4
Constraint 8	2	0	8	8	10
Constraint 9	0	2	4	2	Infinity
Constraint 10	0	3	3	0	Infinity
Constraint 11	0	4	4	0	Infinity
Constraint 12	0	0	6	6	Infinity
Constraint 13	0	0	2	2	Infinity

Source: Authors

The solution of the model is presented in Table 7, which shows the solution to the problem. It includes the decision variable value, contribution of the objective and reduced costs of each decision variable. This also indicates the status of whether the decision variable is in the final basis. When the optimal solution is achieved, the result are the values listed in the table.

The reduced costs: The reduced cost of the non-basic variables (the variables whose value is zero in the optimum solution) provide us information about how much the objective coefficient of these variables should be increased to have a positive value of those variables in the optimum solution.

In the example, reduced cost of a current non-basic variable Y_{24} is 2. It means the current coefficient of this variable which is now 2.5 must decreased by -2. That means the coefficient would be 0.5 or higher to get a basic value of this variable in the optimum solution (Table 7, column 5).

Sensitivity analysis for OBJ: This analysis shows the ranges of objective function coefficients such

that the current basis holds. For each decision variable, this includes the lower limit and the upper limit allowed for its objective function coefficient so that the variable stays as the basic variable. This is also called the range of optimality. The analysis is available when the optimal solution is achieved.

In our example, the final value of variable X_2 in the objective function is 7. The current coefficient of the variable is 0, allowable max $c(j)$ (Table 7, column 6) is $M(\text{infinity})$ and allowable Min $c(j)$ (Table 7, column 5) is -2 It indicates our current solution would remain optimum if normal duration for activity A varies from -2 to $M(\text{infinity})$. While, the current coefficient of the variable Y_{24} is 2.5, allowable Min $c(j)$ is 0.5 and allowable Max $c(j)$ is $M(\text{infinity})$. It indicated our current solution would remain optimum if normal duration for activity varies from 0.5 to $M(\text{infinity})$.

Solution summary in Table 8 specially column 3 (Solution value) or column 2 (Basis Status) indicates that activities A, C, E are critical activities. This table contains some important columns.

Table 8 Solution list

Variable	Status	Value
X1	NONBasic	0
X2	Basic	7
X3	Basic	5
X4	Basic	11
X5	Basic	13
Y12	Basic	8
Y13	Basic	2
Y24	NONBasic	0
Y34	NONBasic	0
Y25	Basic	6
Y45	Basic	2
slack 1	NONBasic	0
surplus 2	NONBasic	0
surplus 3	NONBasic	0
surplus 4	NONBasic	0
surplus 5	NONBasic	0
surplus 6	NONBasic	0
surplus 7	NONBasic	0
slack 8	NONBasic	0
slack 9	Basic	2
slack 10	Basic	3
slack 11	Basic	4
slack 12	Basic	0
slack 13	Basic	0
Optimal Value (Z)		21

Source: Authors

Total cost for crashing will be \$21,000. The manual approach of crashing time is a time-consuming process. It requires the trial and error method to get the optimal result. The Linear Programming solution gives us some flexibility by providing a sensitivity analysis of the mathematical model.

5. Conclusion

This paper addressed the problem of the application of project scheduling in a General Maintenance

project. These models provide us systematic and logical approaches for decision making and ultimately increase the effectiveness of the decision. The solution of these models by software package (POM-QM) provides the duration of project completion in normal and crash conditions, and gives us some flexibility by providing a combined report of the problem, which includes the solution value, contribution to the objective, reduced cost and range of optimality for each decision variable and right-hand side, surplus or slack, shadow price.

REFERENCES

1. Agyei, W. (2015), "Project Planning And Scheduling Using PERT And CPM Techniques With Linear Programming: Case Study", *International Journal of Scientific & Technology Research*, Vol. 4, No. 8, pp. 222-227.
2. Barković, D. (2011). *Uvod u operacijski management*. Osijek: Josip Juraj Strossmayer University of Osijek, Faculty of Economics in Osijek.
3. Čala, I. (1983). *Održavanje i remont*. Zagreb: Faculty of Mechanical Engineering and Naval Architecture.
4. Dilworth, J. B. (1992). *Operations Management*. New York: McGraw-Hill Inc.
5. Elmabrouk, O. M. (2012), "Scheduling Project Crashing Time using Linear Programming Technique", *Proceedings of the 2012 International Conference on Industrial, Engineering and Operations Management*, Istanbul, July 3-6, pp. 308-316.
6. Elmabrouk, O. M. (2012), "A Linear Programming Technique for the Optimization of the Activities in Maintenance Projects", *International Journal of Engineering & Technology*, Vol. 11, No. 1, pp. 24-25.
7. Holjevac, Ž. (1993). *Računovodstvo poduzetnika, Knjiga II*. Zagreb: Računovodstvo, revizija i financije.
8. Islam, M., Rana, B., Rafique, S., Aziza. T. (2004), "Crashing Project Time with Least Cost: A Linear Programming Approach", *Journal of Business Research*, Vol. 6, pp. 13-28.
9. Jukić, J. (2000). *Prilog razvoju modela upravljanja remontom složenih tehničkih sustava*. Master's thesis. Slavonski Brod: Mechanical Engineering Faculty
10. Tomić, M., Adamović, Ž. (1986). *Pouzdanost u funkciji održavanja tehničkih sistema*, Belgrade: Tehnička knjiga.
11. Selaković, M. (1987). *Organizacija proizvodnje*. Rijeka: Faculty of Engineering.
12. Selaković, M. (1994). *Organizacija poslovnih sistema*. Rijeka: Faculty of Engineering.
13. Stevenson, W. J. (1989). *Introduction to Management Science*. Boston: Irwin.
14. Taylor, B. W. (2010). *Introduction to Management Science*. Boston: Pearson.
15. Vila, A., Leicher, Z. (1983). *Planiranje proizvodnje i kontrola rokova*. Zagreb: Informator.
16. Wakas, S. K., Leong, W. J. (2009), "A Linear Programming Approach for the Project Controlling", *Research Journal of Applied Sciences*, Vol. 4, No. 5, pp. 202-212.
17. Weiss, H. (2006). *POM-QM FOR WINDOWS Version 3*. Pearson: Prentice Hall.

Dražen Barković

Josip Jukić

OPTIMIZACIJA VREMENA I TROŠKA PROCESNOM TEHNIKOM

SAŽETAK

U ovome se radu raspravlja o nekim konceptima dviju usko povezanih tehnika operacijskih istraživanja, metode kritičnoga puta i linearnoga programiranja, kako bi se opisale suvremene modelske strukture koje su od velike vrijednosti u analizi produženoga planiranja horizonta projekta loma vremena i troškova. Aktivnosti su podvrgnute lomu vremena i troškova koristeći linearno programiranje. Pojednostavljeno predstavljanje maloga projekta i model linearnoga programiranja formulirani su kako bi se predstavio sustav. Ta je metoda jednostavna, primjenjiva na veliku mrežu, generira kraće vrijeme računanja i niži trošak uz povećanje robusnosti.

Ključne riječi: metoda kritičnoga puta, linearno programiranje, lom vremena, održavanje